

Research Idea

Speckle Contrast Reduction with a Visible VCSEL Projector

Metin Sabuncu[‡], İsmail Yilmazlar[§]

[‡] Dokuz Eylül University, Izmir, Turkey

[§] Vestel Electronics, Manisa, Turkey

Corresponding author: Metin Sabuncu (metin.sabuncu@deu.edu.tr)

Reviewable v1

Received: 17 Jun 2016 | Published: 24 Jun 2016

Citation: Sabuncu M, Yilmazlar İ (2016) Speckle Contrast Reduction with a Visible VCSEL Projector. Research Ideas and Outcomes 2: e9597. doi: [10.3897/rio.2.e9597](https://doi.org/10.3897/rio.2.e9597)

Abstract

Background

Speckle contrast reduction in a laser projector that has a VCSEL emitting in the visible spectrum as its light source can be achieved electronically. Employing a drive circuit enables exciting independent longitudinal modes of the VCSEL.

New information

By modulating the VCSEL current continuously with a triangular wave rather than with pulses, the speckle noise could be reduced.

Keywords

Vertical cavity surface emitting lasers; visible VCSEL; speckle

Overview and background

VCSEL is an acronym that stands for vertical cavity surface emitting laser (Choquette and Hou 1997). The VCSEL is a semiconductor laser that emits light from its top surface. The VCSEL has many advantages from a manufacturing point of view. They are simple to assemble and are very reliable (Helms et al. 2004). Recent announcements of high power VCSEL systems look promising for the consumer electronics market (Seurin 2012, Graham et al. 2015). Having VCSEL systems that emit in the visible spectrum will allow for finally realizing VCSEL based projection systems. All laser based display and projection systems however suffer from speckle noise. Speckle arises due to the high coherence of laser light and degrades the image quality. Speckle noise should be kept below certain limits in laser-based cinema projectors and also laser imaging systems (Verschaffelt et al. 2015). Using a low coherent light source or using massively-parallel detection and frequency-domain ranging can help reduce the speckle problem in OCT imaging (Desjardins et al. 2006, Sabuncu and Akdoğan 2015, Sabuncu and Akdoğan 2014, Sabuncu and Özdemir 2015).

Objectives

Like all other laser based projectors a VCSEL based projection system will also suffer from speckle noise. It is therefore important to devise methods that reduce speckle noise in VCSEL systems. Pulsed current modulation was used in an infrared VCSEL system to reduce speckle noise (Riechert et al. 2008). Recently it was shown that a pulsed current reduced the spatial coherence of a visible VCSEL (Verschaffelt and 2016). In this work, we propose continuous triangular modulation of the VCSEL drive current to achieve effective speckle reduction.

Implementation

The VCSEL drive current modulator circuit scheme and the corresponding block diagram of the drive circuit is given in Fig. 1. The circuit consists of a voltage source, modulator, current limiter and overvoltage protector. LD denotes the VCSEL laser diode module emitting light in the visible spectrum at around a central wavelength of 681 nm. The shape and the level of the VCSEL drive current are determined by the circuit components: Rfb1, Rfb2, Cfb, M1, and DSTM1. U2 and Rlim are used to limit the current. D1 protects the circuit from overvoltage and reverse voltages. LM117 Integrated circuit and the limiting resistor Rlim are used to limit the maximum allowed current of the VCSEL. In order to modulate the VCSEL with triangular waves rather than pulses, a square wave pulse is applied to the gate of M1 with DSTM1 while Cfb is connected. By changing Cfb, the slope of the triangular wave can be tuned (Yilmazlar and Sabuncu 2015).

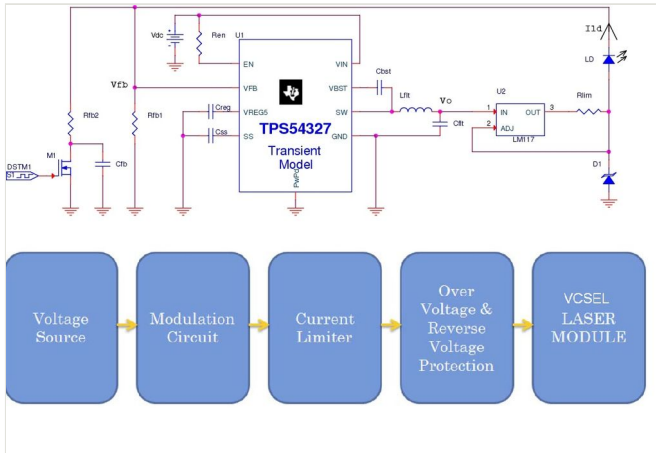

Figure 1.

The circuit that allows for triangular wave modulation of the VCSEL drive current. The corresponding block diagram of the circuit scheme that drives the VCSEL is given below the drive circuit.

VCSEL Speckle Reduction

The visible VCSEL spectrum at various drive currents is given in the 680 nm [VCSEL datasheet](#). The visible VCSEL emits light between 678 and 684 nm depending on its drive current.

When the drive current is modulated with a continuous wave these 4 independent modes are excited. This will result in speckle reduction in the projected image (Yilmazlar and Sabuncu 2015).

Theoretically the speckle is quantified by the speckle contrast ratio (C) (Freund 2007),

$$C = \sigma/I$$

where σ represents the standard deviation of the picture and I stands for the mean intensity of the picture.

By dividing the initial speckle ratio C_i by the final speckle ratio C_f , the speckle reduction factor (R) is calculated:

$$R = C_i/C_f$$

The speckle reduction factor will depend on the number of the different excited modes and their relative intensities.

When the VCSEL drive current is driven with a modulated current between 4 and 16 mA, 4 modes will be excited. The maximum and minimum value of the drive current are adjusted by the circuit elements.

The maximum speckle reduction factor for triangular modulation will be $R \approx 2$. If however the VCSEL drive current were to be modulated with a square wave (pulsed) then only two modes would be excited resulting in a maximum speckle reduction factor $R \approx 1.41$. Speckle reduction will be important when using VCSELs in projection systems (Zheng et al. 2008, Shayesteh et al. 2015).

We proposed a method of speckle contrast reduction in a laser projector that has a VCSEL emitting in the visible spectrum as its light source. Effective speckle reduction can be achieved electronically by modulating the VCSEL current continuously in a triangular fashion rather than pulsed.

Hosting institution

Department of Electrical and Electronics Engineering, Dokuz Eylul University

References

- Choquette KD, Hou HQ (1997) Vertical-cavity surface emitting lasers: moving from research to manufacturing. Proceedings of the IEEE 85 (11): 1730-1739. DOI: [10.1109/5.649649](https://doi.org/10.1109/5.649649)
- Desjardins AE, Vakoc BJ, Tearney GJ, Bouma BE (2006) Speckle Reduction in OCT using Massively-Parallel Detection and Frequency-Domain Ranging. Optics Express 14 (11): 4736. DOI: [10.1364/oe.14.004736](https://doi.org/10.1364/oe.14.004736)
- Freund I (2007) Joseph W. Goodman: Speckle Phenomena in Optics: Theory and Applications. Journal of Statistical Physics 130 (2): 413-414. DOI: [10.1007/s10955-007-9440-8](https://doi.org/10.1007/s10955-007-9440-8)
- Graham L, Chen H, Cruel J, Guenter J, Hawkins B, Hawthorne B, Kelly D, Melgar A, Martinez M, Shaw E, Tatum J (2015) SPIE OPTO. Vertical-Cavity Surface-Emitting Lasers XIX, 10 pp. URL: <http://dx.doi.org/10.1117/12.2080064> DOI: [10.1117/12.2080064](https://doi.org/10.1117/12.2080064)
- Helms C, Aeby I, Luo W, Herrick R, Yuen A (2004) SPIE. Vertical-Cavity Surface-Emitting Lasers VIII, 12 pp. URL: <http://dx.doi.org/10.1117/12.539282> DOI: [10.1117/12.539282](https://doi.org/10.1117/12.539282)
- Riechert F, Verschaffelt G, Peeters M, Bastian G, Lemmer U, Fischer I (2008) Speckle characteristics of a broad-area VCSEL in the incoherent emission regime. Optics Communications 281 (17): 4424-4431. DOI: [10.1016/j.optcom.2008.05.004](https://doi.org/10.1016/j.optcom.2008.05.004)
- Sabuncu M, Akdogan M (2015) Photonic Imaging with Optical Coherence Tomography for Quality Monitoring in the Poultry Industry: a Preliminary Study. BJPS 17 (3): 319.

- Sabuncu M, Akdoğan M (2014) Utilizing Optical Coherence Tomography in the Nondestructive and Noncontact Measurement of Egg Shell Thickness. The Scientific World Journal 2014: 1-4. DOI: [10.1155/2014/205191](https://doi.org/10.1155/2014/205191)
- Sabuncu M, Özdemir H (2015) Recognition of fabric weave patterns using optical coherence tomography. The Journal of The Textile Institute 11: 147. DOI: [10.1080/00405000.2015.1114791](https://doi.org/10.1080/00405000.2015.1114791)
- Seurin J (2012) High-Power VCSEL Arrays. Springer Series in Optical Sciences. URL: http://dx.doi.org/10.1007/978-3-642-24986-0_8 DOI: [10.1007/978-3-642-24986-0_8](https://doi.org/10.1007/978-3-642-24986-0_8)
- Shayesteh MR, Darvish G, Ahmadi V (2015) A low-threshold high-index-contrast grating (HCG)-based organic VCSEL. Optics & Laser Technology 75: 173-176. DOI: [10.1016/j.optlastec.2015.06.020](https://doi.org/10.1016/j.optlastec.2015.06.020)
- Verschaffelt G, der Sande G (2016) Spatial coherence properties of pulsed red VCSELs. IEEE Photonics Technology Letters 12: 1-1. DOI: [10.1109/lpt.2016.2524064](https://doi.org/10.1109/lpt.2016.2524064)
- Verschaffelt G, Roelandt S, Meuret Y, den Broeck W, Kilpi K, Lievens B, Jacobs A, Janssens P, Thienpont H (2015) Speckle disturbance limit in laser-based cinema projection systems. Scientific Reports 5: 14105. DOI: [10.1038/srep14105](https://doi.org/10.1038/srep14105)
- Yilmazlar I, Sabuncu M (2015) Implementation of a Current Drive Modulator for Effective Speckle Suppression in a Laser Projection System. IEEE Photonics Journal 7 (5): 1-6. DOI: [10.1109/jphot.2015.2478697](https://doi.org/10.1109/jphot.2015.2478697)
- Yilmazlar I, Sabuncu M (2015) Speckle noise reduction based on induced mode Hopping in a semiconductor laser diode by drive current modulation. Optics & Laser Technology 73: 19-22. DOI: [10.1016/j.optlastec.2015.04.014](https://doi.org/10.1016/j.optlastec.2015.04.014)
- Zheng G, Wang B, Fang T, Cheng H, Qi Y, Wang YW, Yan BX, Bi Y, Wang Y, Chu SW, Wu TJ, Xu JK, Min HT, Yan SP, Ye CW, Jia ZD (2008) Laser Digital Cinema Projector. Journal of Display Technology 4 (3): 314-318. DOI: [10.1109/jdt.2008.924163](https://doi.org/10.1109/jdt.2008.924163)